



Volker Nolte and Allison Sheard

## Rigging for the Adaptive Rower



## Rigging for the Adaptive Athlete

**FOCUS**

Presentation will cover effective rigging for adaptive rowing, primarily focused on the TA and Arms-only athletes.

**GROUP DISCUSSION**

Discussion on the disability-specific rigging issues related to the following:

- Amputations
- Spinal Cord Injuries
- Cerebral Palsy
- Visual Impairment/Blindness

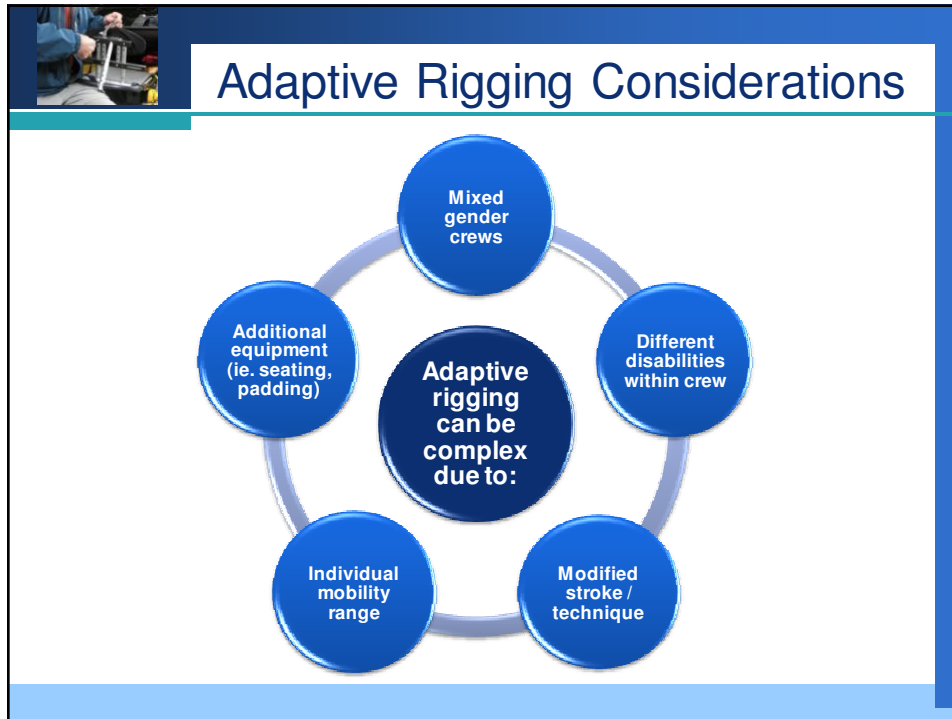

**LTA Classification**

- **Leg/Trunk/Arms (LTA)**
  - Row with full rowing stroke
  - Can include individuals with MS, Visual Impairments, Amputation, Cerebral Palsy, Intellectual Disability, etc
  - Internationally race as a mixed coxed four,
  - Domestically can race as 1x, 2+, 2x, 4-, 4+, 4x, 8+ (mixed or single gender)



## Equipment - LTA

**Boats:**

- Paralympics: Wintech stern coxed four
- World championships: stern coxed four (any manufacturer)
- National/domestic: any club boat

**Other equipment:**

- Limited requirement for additional equipment
- Individually driven



## TA Classification

- **Trunk/Arms (TA)**
  - Row with body swing and arms, using a fixed seat
  - Can include individuals with spinal cord injury, cerebral palsy, MS, amputation, etc
  - Internationally race as a mixed double,
  - Domestically can race as 1x, 2x (mixed or single gender)







## Equipment - TA

**Boats:**

- Paralympics: Wintech double
- World championships: Wintech double
- National/domestic: Wintech 2x or other stable shell (1x or 2x)

**Other equipment:**

- Fixed seat
- Strapping at pelvis

## Arms Only Classification

- **Arms only (A)**
  - Row with arms only, using a fixed seat with back support
  - Can include individuals with Spinal Cord Injury, Polio, Cerebral Palsy, MS, Spina Bifida, etc
  - Internationally race as a single,
  - Domestically can race as a 1x or 2x (mixed or single gender)





## Equipment – Arms Only

### Boats:

- Paralympics: Wintech single
- World championships: Wintech single
- National/domestic: Wintech 1x or other stable shell (2x or 1x)





### Other equipment:

- Pontoons req'd
- Fixed seat
- Strapping at chest and pelvis level

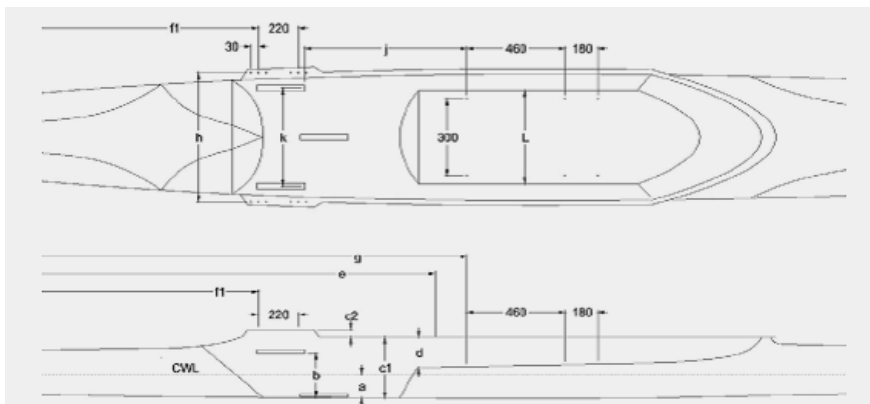

## FISA Adaptive Boat Specifications





## FISA Adaptive Boat Specifications

Adaptive specifications      All measures in mm

	A 1x	A 1x HW	TA 2x	LTA 4+	LTA 4+ SLW
Average Kg	75	90	75	75	80
a Crew water line - Lowest Point of Hull	80	95	88	150	150
b Bottom Stretcher Track - Top Track	140	140	130	130	130
c 1 Saxboard - Lowest Point of Hull	243	253	265	340	333
c 2 Saxboard - Wing Flange	20	20	0	0	0
d Saxboard - Deck	107	107	115	135	135
e Stern tip to Rigger Pin	2780	2760	3475	4210	4100
f 1 Wing hole from stern	2110	2110	2825	3560	3440
h Bow			555	520	500
2 (Length rigger bolt spacing 220mm)				540	500
3 (Boat flange has optional rigger holes 30mm fore or aft)				540	500
Stern	510	510	555	520	500
g Stern tip to stern seat track bolt (Stern bolt – Mid bolt 480mm) (Mid bolt – to bow bolt 180mm) Width of seat tracks 300 mm	2890	2990	3590		
j Stern seat track bolt – Bow end of foot stretcher track (Track is 250 mm long) (Track in single can be moved 130 to stern)	500	500	470		
k Width of stretcher tracks	345	345	345	310	310
L Width of Seat Deck	425	425	400-410		

Note: Length measures relate to stroke station, add for each station to bow for the following distance

- TA 2x 1400
- LTA 4+ 1400
- LTA 4+ LW 1250

+/- 1 kg change of the crew average weight changes the depth of the CWL +/- 1mm approx.



## LTA Rigging Considerations

LTA athletes are rigged based on standard rigging, taking the following into consideration:

- Mixed gender crews (therefore different heights and strength)
  - Oar loads (potential varying inboards)
  - Rigger heights
- Differing disabilities may affect the boat set up
  - Boat balance can be difficult (side discrepancies due to amputations, underdeveloped muscles, etc)





## TA Rigging Considerations

<p><b><u>Lwt SM 2x Range</u></b>  <b>Oar length:</b> 2.87 – 2.90 m  <b>Inboard:</b> 0.86 – 0.89 m  <b>Spread:</b> 1.57 m</p>	<p><b><u>Adaptive 2x Range</u></b>  <b>Oar length:</b> 2.78 – 2.87 m  <b>Inboard:</b> 78 m  <b>Spread:</b> 1.58 – 1.60 m  <b>Overlap:</b> none</p>
--	--



## TA Rigging Considerations

**Oars:**

- Elimination of oar handle cross over
- Move to shorter blade usage

**Rigging:**

- Custom rigging span
- Oarlocks rigged to equal height

**Seat:**

- Fixed seat
- Seat back use dependant upon individual need







## Arms-only Rigging Considerations

<p><u>Lwt SM 1x Range</u>  <b>Oar length:</b> 2.87-2.90m  <b>Inboard:</b> 0.87-0.90m  <b>Spread:</b> 1.58-1.59 m</p>	<p><u>Adaptive AM1x (CAN 2007)</u>  <b>Oar length:</b> 2.72 m  <b>Inboard:</b> 0.67 m  <b>Spread:</b> 1.40-1.42 m  <b>Overlap:</b> none</p>	<p><u>Adaptive 1x Range (UK 2007)</u>  <b>Oar length:</b> 2.65-2.75m  <b>Inboard:</b> 0.57m (+)  <b>Spread:</b> 1.15-1.25 m  <b>Overlap:</b> none</p>
--	---	---

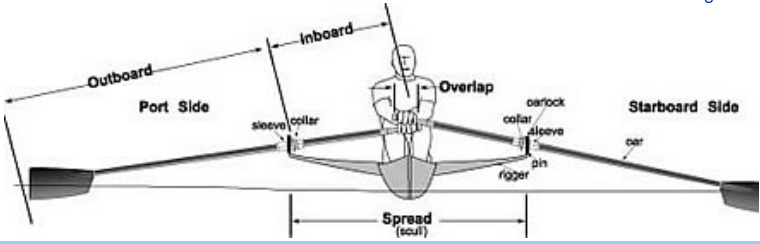
Moving the spread in toward the hull will allow for a longer stroke arc, and increase the load on the oar. Shortening the blade will therefore decrease the resulting load.

## Arms-only Rigging Considerations

**Oars:**

- Elimination of oar handle cross over
- Move to shorter blade usage

**Rigging:**



- Custom rigging span
- Oarlocks rigged to equal height
- Need to consider the seat placement (with padding) within the rigging measurements
- Remove footplate if additional space required to move to the stern

**Seat:**

- Seat back angle - 90°

**Pontoons:**

- Pontoon depth can impact rigging height
- Some evidence that pontoons at water level have a more slowing effect than pontoons more submerged (due to resulting lift effect on the hull)



## Arms-only Rigging Considerations

Seats gaining complexity and require increased individualization.  
Recommendation is for high level athletes to consider development of custom seats.





## Disability-specific Rigging

While each athlete's disability will present unique rigging requirements, the following discussion is intended to share some issues which have been identified. Proper rigging for these unique disability issues can help with injury prevention.

- Amputations
- Spinal Cord Injuries
- Cerebral Palsy
- Visual Impairment/Blindness

Coaches are encouraged to share their experiences.